



VT320WI+C

32GHz Waveguide Cross Coupler

Description

Cross couplers are typically used for power sampling, frequency monitoring and standing wave testing. This is a four-ports configuration cross coupler. The directivity is over 18 dB. The coupling level can be custom made ranging from 20 dB to 60 dB. The flange type, connector type and sizes can be custom made as per customer's specific requirements.

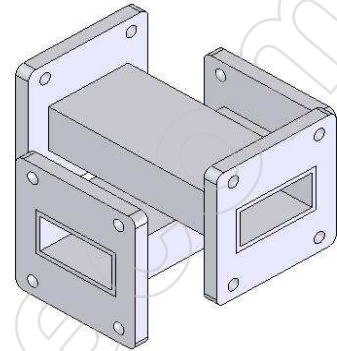

Specifications

MODEL NO	VT320WI+C
FREQ RANGE (GHz)	26.5-40
VSWR	1.05
COUPLING LEVEL(dB)	20-60
DIRECTIVITY (dB) Min	18
OPERATION TEMP (°C)	-40~+70
SIZE H*W*L (mm)	50*50
FLANGE TYPE	FBP/FBM//FBE
WAVEGUIDE TYPE	WR28
CONNECTOR	-
MATERIAL	Al/Cu

Outline Drawings

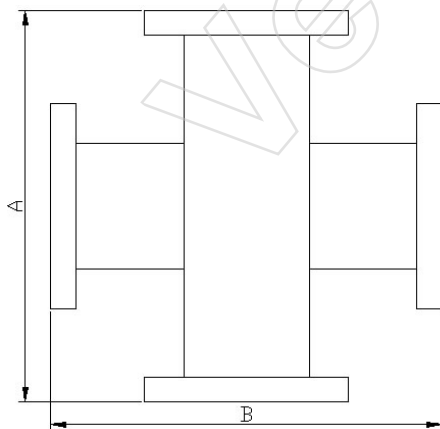

Revision History

Date	Revision	Changes
01-Jul-2006	1	First release

Vector Telecom

Information furnished is believed to be accurate and reliable. However, Vector Telecom assumes no responsibility for the consequences of use of such information nor for any infringement of patents or other rights of third parties which may result from its use. No license is granted by implication or otherwise under any patent or patent rights of Vector Telecom. Specifications mentioned in this publication are subject to change without notice. This publication supersedes and replaces all information previously supplied. Vector Telecom products are not authorized for use as critical components in life support devices or systems without express written approval of Vector Telecom.

The Vector Telecom logo is a registered trademark of Vector Telecom Pty Ltd.

© 2006 Vector Telecom Pty Ltd - All rights reserved

Email: sales@vectortele.com

www.vectortele.com